

Parker Seals | Parker E5 rod seal

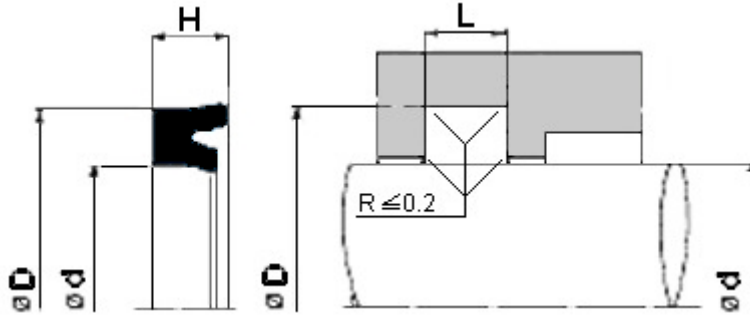

Compound N3578
Max. Pressure 16 bar.
Working Temp. -30 +80 °C.
Max. Speed 1 m/sec.



SEAT

d f9 rod	D H9	H	L +0.5	E5 code
5	9	2.5	3	E5 0005 N3578
6	12	4	4.5	E5 0026 N3578
8	13	4	4.5	E5 0070 N3578
8	14	4	4.5	E5 0080 N3578
10	15	3.5	4	E5 1015 N3578
10	16	4.5	5	E5 1016 N3578
10	18	5.5	6	E5 1019 N3578
12	19	4.5	5	E5 1219 N3578
12	20	5.5	6	E5 1220 N3578
12	22	7.5	8	E5 1222 N3578
14	22	5	5.5	E5 1422 N3578
16	22	4	4.5	E5 1622 N3578
18	24	4	4.5	E5 1824 N3578
20	28	5.5	6	E5 2028 N3578
20	30	7.5	8	E5 2030 N3578
20	32	7.5	8	E5 2032 N3578
22	30	5.5	6	E5 2230 N3578
22	32	6.5	7	E5 2232 N3578
25	35	7	7.5	E5 2534 N3578
25	35	7.5	8	E5 2535 N3578
30	40	7.5	8	E5 3040 N3578
35	45	7.5	8	E5 3545 N3578
40	50	7.5	8	E5 4050 N3578