

## Parker Seals | Parker Z9 rod seal

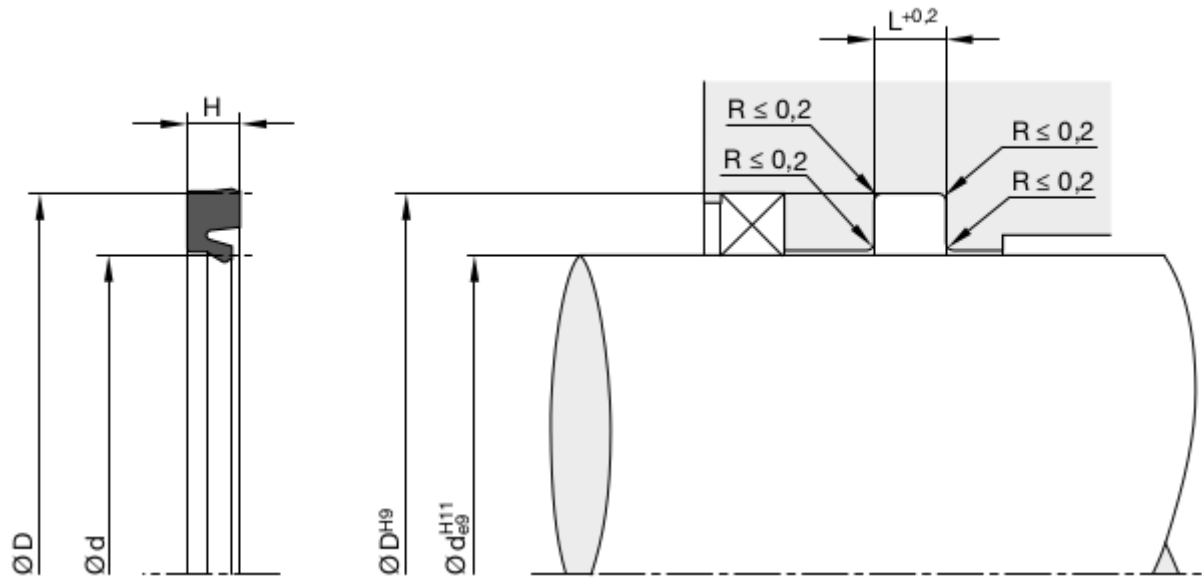

Compound N3580  
 Max. Pressure 16 bar.  
 Working Temp. -20 +80 °C.  
 Max. Speed 1 m/sec.



## SEAT

d h9 rod	D H9	H	L +0.5	Z9 code
3	6	2.2	2.6	Parker Z9 0303 N3580
3	6.5	2.2	2.6	Parker Z9 0304 N3580
10	16	2.55	35	Parker Z9 1004 N3580
12	18	2.55	3	Parker Z9 1204 N3580
16	22	2.55	3	Parker Z9 1605 N3580
17	24	2.55	3	Parker Z9 1724 N3580