

Parker Seals | Parker A1 Wiper Ring

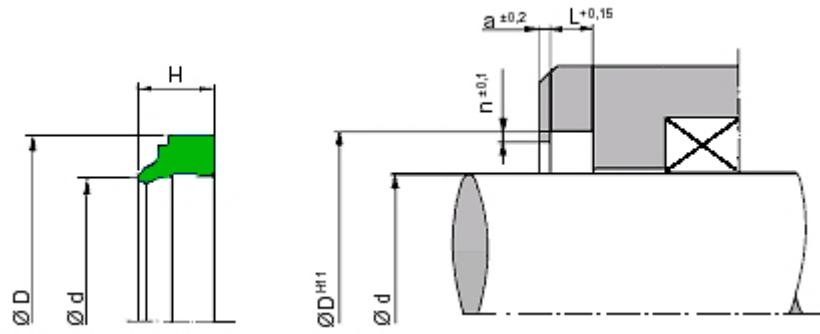

Compound P5008
 WorkingTemp. -35 +110 °C.
 Max. Speed 2 m/sec.



SEAT

d f7 rod	D H11	H	L +0.15	a	n	A1 code
16	24	7	4	1	1	A1 1025 P5008
20	28	7	4	1	1	A1 2005 P5008
25	33	7	4	1	1	A1 2025 P5008
28	36	7	4	1	1	A1 2035 P5008
30	38	7	4	1	1	A1 3005 P5008
35	43	7	4	1	1	A1 3025 P5008
36	44	7	4	1	1	A1 3030 P5008
40	48	7	4	1	1	A1 4005 P5008
45	53	7	4	1	1	A1 4030 P5008
50	58	7	4	1	1	A1 5005 P5008
55	63	7	4	1	1	A1 5035 P5008
56	64	7	4	1	1	A1 5040 P5008
60	68	7	4	1	1	A1 6005 P5008
63	71	7	4	1	1	A1 6020 P5008
70	78	7	4	1	1	A1 7005 P5008
80	88	7	4	1	1	A1 8002 P5008
80	92	10	5.5	1.5	1.5	A1 8003 P5008
90	98	7	4	1	1	A1 9005 P5008
100	108	7	4	1	1	A1 A010 P5008
125	137	10	5.5	1.5	1.5	A1 C020 P5008
140	152	10	5.5	1.5	1.5	A1 E010 P5008
150	162	10	5.5	1.5	1.5	A1 F005 P5008
160	172	10	5.5	1.5	1.5	A1 G010 P5008
170	182	10	5.5	1.5	1.5	A1 H010 P5008