

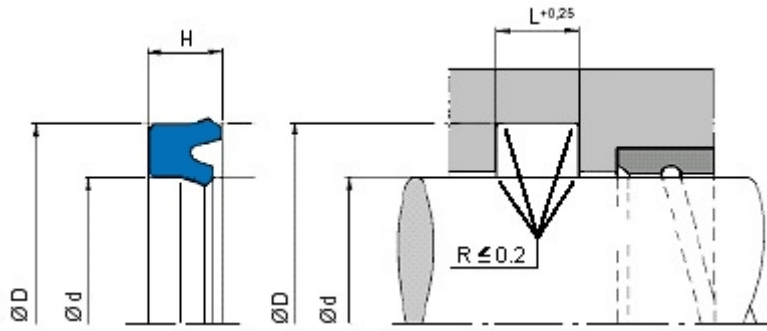

Elastomer Seals |Rod seal S03 hydraulics



Material: P95-R198.
Pression max. 400 bar.
Temp.: -30 +105 °C.
Speed Max.: 0.5 m/sec.



SEAT

d f7 rod	D H11	H	L +0.25	code
6	14	5.7	6.3	S03 006x014x06.3 P95-R198
8	14	5	5.6	S03 008x014x05.6 P95-R198
10	18	5.7	6.3	S03 010x018x06.3 P95-R198
14	22	7.3	8	S03 014x022x08 P95-R198
18	28	8	9	S03 018x028x09 P95-R198
20	28	5.7	6.3	S03 020x028x06.3 P95-R198
20	30	7.3	8	S03 020x030x08 P95-R198
22	30	5.7	6.3	S03 022x030x06.30 P95-R198
22	32	7.3	8	S03 022x032x08.00 P95-R198
28	36	5.7	6.3	S03 028x036x06.30 P95-R198
30	38	5.7	6.3	S03 030x038x06.30 P95-R198
32	42	7.3	8	S03 032x042x08.00 P95-R198
36	46	7.3	8	S03 036x046x08.00 P95-R198
40	48	5.7	6.3	S03 040x048x06.30 P95-R198
40	50	10	11	S03 040x050x11.0 P95-R198
45	55	7.3	8	S03 045x055x08.0 P95-R198
45	55	10	11	S03 045x055x11.0 P95-R198
50	60	7.3	8	S03 050x060x08.0 P95-R198
50	60	10	11	S03 050x060x11.0 P95-R198
55	70	10	11	S03 055x070x11.0 P95-R198
56	71	11.4	12.5	S03 056x071x12.5 P95-R198
60	75	10	11	S03 060x075x11.0 P95-R198
63	75	10	11	S03 063x075x11.0 P95-R198
63	78	11.4	12.5	S03 063x078x12.5 P95-R198
80	90	7	8	S03 080x090x08.0 P95-R198
80	95	11.4	12.5	S03 080x095x12.5 P95-R198
80	100	12	13	S03 080x100x13.0 P95-R198
85	100	9	10	S03 085x100x10.0 P95-R198
85	100	12	13	S03 085x100x13.0 P95-R198
90	105	11.4	12.5	S03 090x105x12.5 P95-R198
100	120	14.5	16	S03 100x120x16.0 P95-R198
105	120	10	11	S03 105x120x11.0 P95-R198
105	125	14.5	16	S03 105x125x16.0 P95-R198
110	130	14.5	16	S03 110x130x16.0 P95-R198
125	145	14.5	16	S03 125x145x16.0 P95-R198



130	150	15	16	S03 130x150x16.0 P95-R198
140	160	14.5	16	S03 140x160x16.0 P95-R198
150	170	15	16	S03 150x170x16.0 P95-R198
160	180	15	16	S03 160x180x16.0 P95-R198
180	205	18.2	20	S03 180x205x20.0 P95-R198
220	250	22.7	25	S03 220x250x25.0 P95-R198

FURTHER DIMENSIONS WITH STANDARD CROSS SECTION

Image

d h7 rod dimensional range	D H11	H	L +0.25
4 - 30	d + 7	5	5.6
6 - 60	d + 8	5.7	6.3
10 - 100	d + 10	7.3	8
14 - 150	d + 10	8.2	9
25 - 160	d + 15	9	10
25 - 200	d + 10	10	11
100 - 300	d + 20	14.5	16
150 - 600	d + 25	18.2	20
300 - 1200	d + 30	22.7	25

FURTHER DIMENSIONS UPON REQUEST