

## Rotary shaft seals | Energized Rotary Enerseal U

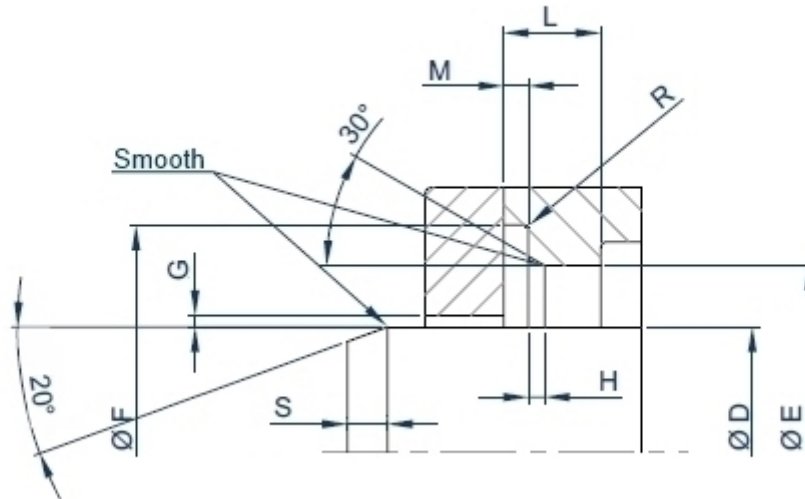

Spring Energized Rotary Seals

### Spring Energized Rotary Seals

Jacket in PTFE compound, PEEK, UHMW-PE, PU 54Sh.D.

Spring in Aisi 301, Elgiloy, Hastelloy and **NACE approved Inconel X750**. An optional FDA approved Silicone filling is available.

[Homepage](#)  
[Rotary Shaft](#)  
[Seals](#)



## SEAT

housing class	<b>D</b> dimensional range	<b>E</b> groove diameter	<b>F</b> flange groove diameter	<b>L</b> groove width	<b>M</b> flange groove width	<b>H</b> chamfer	<b>S</b> chamfer	<b>R</b> max	<b>G</b> max. radial gap
	<b>f7</b>	<b>H9</b>	<b>H12</b>	<b>H12</b>	<b>+0/-0.1</b>				
RUL	5 - 240	D+4.52	D + 10.4	3.6	0.65	0.8	2.5	0.3	0.05
RUH	25 - 400	D+6.15	D + 13.8	4.8	0.75	1.35	3.0	0.4	0.08
RUN	45 - 650	D+9.45	D + 20.2	7.1	1	1.4	5.5	0.5	0.10
RUM	80 - 1100	D+12.11	D + 26.4	9.5	1.25	2.3	8.5	0.5	0.12

### Coding example

housing class RUN  
 profile code 118  
 rod 30  
 materials: jacket Neuflon 020 spring Aisi 301

**Roto-Enerseal RUN 118 030 N-020 301**



## FINISHES

SURFACE FINISH ACCORDING WITH FLUID		
application	max Ra $\mu\text{m}$ dynamic surface	max Ra $\mu\text{m}$ static surface
CRYOGENICS	0,1	0,2
FREON HELIUM HYDROGEN	0,2	0,3
AIR NITROGEN ARGON METHANE FUELS	0.2	0.4
WATER OIL	0.3 - 04	0.6
ROTARY SEALS		
<b>Shaft surface</b> Ra 0.2 - 0.3 micron max. Rz 1.0 - 2.5 micron max. R max. < 4 micron	<b>Shaft hardness</b> 55 HRC min. for pressure up to 5 bar 60 HRC min. for pressure > di 5 bar 60 HRC for speed > 4m/sec	<b>Surface treating deep</b> 0.3 mm min.



## AVAILABILITY

**To check the availability:**

- choose profile and compound from the drop-down menu
- input the desired housing class
- input the desired diameter

Once obtained the availability, a request for quotation can be sent.



## MATERIALS

Click compound's code to download the .PDF data sheet. Login required.

### PTFE COMPOUNDS

HD Slippers code	Composition	Approvals	ΔT °C	Description
<a href="#">N-009</a>	Ptfe-oxides		-268 +260	All pourpose on soft surfaces
<a href="#">N-032</a>	Ptfe-carbon		-268 +260	High wear resistance, pneumatic and hydraulic seals
<a href="#">N-197</a>	Ptfe-carbographite	<b>NORSOK</b>	-268 +260	High wear resistance, hydraulic and pneumatic seals
<a href="#">N-043</a>	Ptfe-graphite	<b>FDA</b>	-268 +260	High wear resistance, low friction coefficient.
<a href="#">N-103</a>	Ptfe-carbon fibre	<b>FDA</b>	-268 +260	High wear resistance, low friction coefficient, hard surfaces.
<a href="#">N-033</a>	Ptfe-glass fibre-MoS <sub>2</sub>		-268 +260	Of general use, in lubricated applications, rotary seals
<a href="#">N-060</a>	Ptfe-glass fibre	<b>FDA</b>	-268 +260	All pourpose on hard surfaces
<a href="#">N-067</a>	Ptfe-glass fibre	<b>FDA</b> <b>NORSOK</b>	-268 +260	High wear and creep resistance
<a href="#">N-102</a>	Ptfe-Liquid crystal polymer	<b>FDA - EU</b>	-268 +260	Food & Pharma on soft surfaces
<a href="#">N-088</a>	Ptfe-poliimide		-268 +260	High wear resistance. Soft surfaces
<a href="#">N-074</a>	PEHMW	<b>FDA</b>	-140 +80	High wear and extrusion resistance

### CHOOSING Neuflon-ptfe compound ACCORDING WITH FLUID AND SURFACE

FLUIDS	SURFACES			
	Steel HEC>=30-45 Temp. Mart. Inox Steel Cast Iron HRB<=200 Steel HRC>=45 Cast Iron HRB>200	Galvanic or chemical surfacing HV>=700 Chromium Bronze	Treated Aluminium	Aust. Inox Steel Glass
	<b>NEUFLON-ptfe compounds (standard in bold)</b>			
Hydraulic oil Transmission oil Fire resistant syntetic hydraulic oil	<b>N-031</b> N-032 N-060 N-077 P95-G114	<b>N-031</b> N-032 N-060 N-077 P95-G114	<b>N-032</b> N-074 P95-G114	<b>N-009</b> N-032 N-074 P95-G114
Water and oil/water emulsions	<b>N-032</b> N-060 N-077 N-074	<b>N-032</b> N-060 N-077 N-074	<b>N-032</b> N-074	<b>N-009</b> N-032 N-074
Drugs and food	<b>N-102</b> N-043 N-060 N-074 N-088 P95-G114	<b>N-009</b> N-074 P95-G114	<b>N-009</b> N-074 P95-G114	<b>N-009</b> N-074 P95-G114
Air	<b>N-032</b> N-031 N-043 N-074 P95-G114	<b>N-032</b> N-043 P95-G114	<b>N-032</b> N-074 P95-G114	<b>N-032</b> N-009 N-043 N-074 P95-G114
Steam	<b>N-032</b> N-043	<b>N-032</b>		<b>N-032</b> N-009 N-043
Acids and Bases	<b>N-032</b> N-074	<b>N-032</b> N-043 N-074		<b>N-009</b> N-032 N-043 N-074