

Slipper ptfе Composite seals |Rod Slipper H series

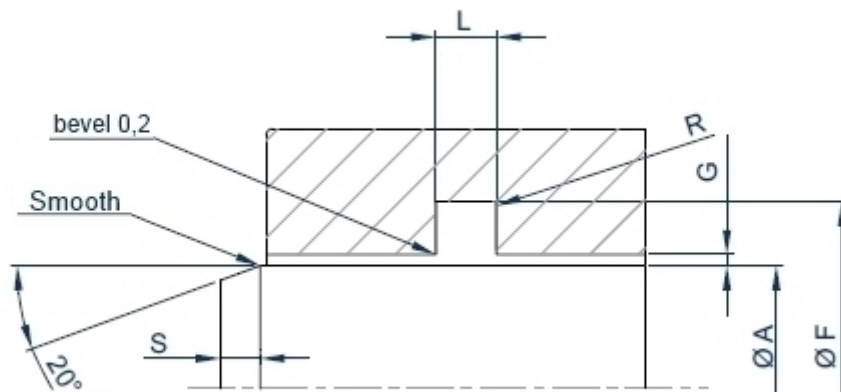

Slipper composite rod seals H series for the most difficult conditions of use, is suggested instead the N series when a fast response to the pressure is required. Resizing is needed if installed in closed grooves



SEAT

Class	A rod diameter range		F groove diameter		L groove width	R	S min	G*	G*				closed groove if >=
	suggested	available	hydraulics	pneumatics					max. radial gap				
									f7	H9	H12	Bar 50	
H1	3-7	3-100	A+4,4	A+4,5	2,2	0,4	1,2	0,4	0,25	0,2	0,15	0,08	11
H2	8-18	8-250	A+6,8	A+7,1	3,2	0,6	2,2	0,6	0,5	0,3	0,2	0,15	13
H3	19-37	10-450	A+9,6	A+10,0	4,2	0,8	2,6	0,65	0,6	0,4	0,25	0,15	15
H4	38-199	15-650	A+14,1	A+14,6	6,3	1	5,6	0,9	0,6	0,4	0,25	0,15	35
H5	200-255	120-1100	A+18,4	A+19,1	8,1	1,5	8,2	1,0	0,7	0,4	0,25	0,15	110
H6	256-1100	120-1100	A+22,0	A+22,7	8,1	1,5	8,2	1,4	1,0	0,5	0,3	0,15	150

G* = G1 + G2 + G3
 G1 = Max. initial clearance
 G2 = Clearance by elastic deformation of the components under pressure
 G3 = Clearance due to the foreseen wear of the guiding elements

Coding example

profile code HCR
 rod 100
 housing class H4
 materials: Neuflon 031 O-Ring NBR

Slipper HCR 100 H4 N-031 NBR

ASSEMBLY

SLIPPER COMPOSITE SEALS ASSEMBLING INSTRUCTIONS

ASSEMBLY ON PISTON IN CLOSED GROOVE AND IN OPEN GROOVE

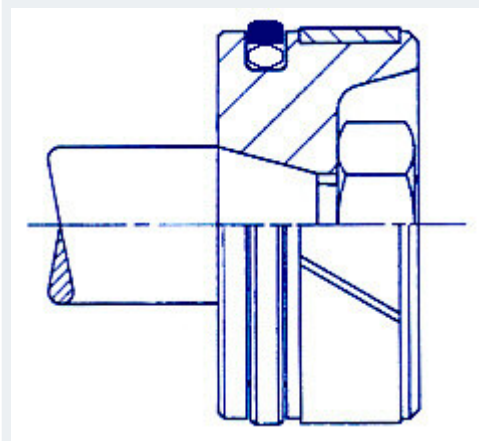

Assembly in closed groove can be carried out manually, however the use of the appropriate equipment guarantees the integrity of the slipper and time-saving insertion.

Assembly in open groove is suggested for slippers exceeding the dimensions shown in dimensional table.

Correctly carried out introduction blunting and the lubrication of the surfaces make assembly easier.

For an easier assembling in closed groove the preheating of the Slipper in oil or water bath at 90-100°C is suggested.



INSERTION AND RECALIBRATION EQUIPMENT FOR INSTALLATION IN CLOSED GROOVES ON THE PISTON



The expander cone brings the Slipper to the diameter of the piston, or to the edge of the groove when other existing grooves must be passed over.

The thruster expands sector by sector, or more simply, in single longitudinal cutting.

Both the cone and thruster can be made in acetal resin (POM), polyester (PBTF) or polyamide (PA6)

The prolonged extended permanence of the Slipper during installation could determine a permanent increase in diameter; therefore fast installation is advised.

Recalibration of the slipper may be opportune using a sleeve before insertion of the piston in the cylinder.

The sleeve also allows the passing over of grooves and threads.

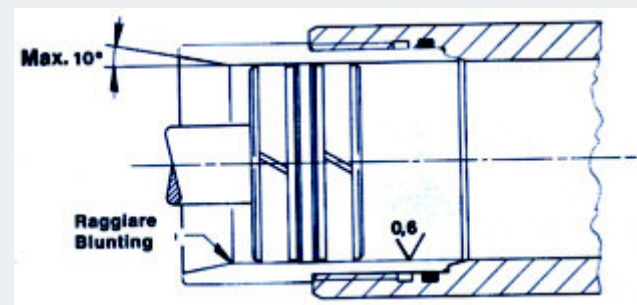

INSTALLATION ON THE CYLYNDER IN CLOSED GROOVE

The Slipper seal can be introduced in the closed groove imposing a reniform deformation.

The radius **R** should never be little then 3 times **S**

Open groove



installation is advised
for rods exceeding
the diameter shown in
dimensional table.

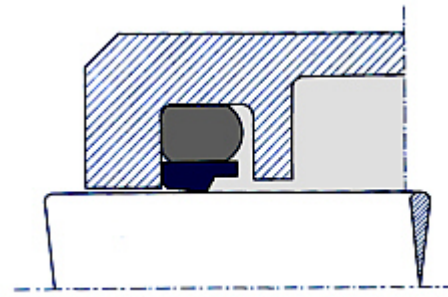

The mono-directional R type Slipper is
installed using this method of positioning
the seal-front towards the pressure.



FINISHES

SURFACE FINISH ACCORDING WITH FLUID		
application	max Ra μm dynamic surface	max Ra μm static surface
CRYOGENICS	0,1	0,2
FREON HELIUM HYDROGEN	0,2	0,3
AIR NITROGEN ARGON METHANE FUELS	0.2	0.4
WATER OIL	0.3 - 04	0.6
ROTARY SEALS		
Shaft surface Ra 0.2 - 0.3 micron max. Rz 1.0 - 2.5 micron max. R max. < 4 micron	Shaft hardness 55 HRC min. for pressure up to 5 bar 60 HRC min. for pressure > di 5 bar 60 HRC for speed > 4m/sec	Surface treating deep 0.3 mm min.



AVAILABILITY

To check the availability:

- choose profile and compound from the drop-down menu
 - input the desired housing class
 - input the desired diameter
- Once obtained the availability, a request for quotation can be sent.



MATERIALS

Click compound's code to download the .PDF data sheet. Registration required.

HD Slippers code	Composition	Color	Approvals	ΔT °C	Description
N-020	Virgin PTFE	white	FDA NORSOK	-268 +260	All purpose, low friction coefficient, extrusion withstanding.
N-009	Ptfe-oxides	blue	FDA	-268 +260	All purpose on soft surfaces
N-031	Ptfe-bronze	green-blue		-268 +260	High wear resistance, hidraulic seals
N-032	Ptfe-carbon	black		-268 +260	High wear resistance, pneumatic and hydraulic seals
N-059	Ptfe-carbographite	black		-268 +260	High wear resistance, hydraulic and pneumatic seals, hard surfaces
N-197	Ptfe-carbographite	black	NORSOK	-268 +260	High wear resistance, hydraulic and pneumatic seals
N-043	Ptfe-graphite	black	FDA	-268 +260	High wear resistance, low friction coefficient.
N-103	Ptfe-carbon fibre	black	FDA	-268 +260	High wear resistance, low friction coefficient, hard surfaces.
N-077	Ptfe-glass fibre-MoS ₂	gray		-268 +260	Of general use, in lubricated applications, rotary seals
N-060	Ptfe-glass fibre	blue	FDA	-268 +260	All purpose on hard surfaces
N-067	Ptfe-glass fibre	white	FDA NORSOK	-268 +260	High wear and creep resistance
N-102	Ptfe-Liquid crystal polymer	beige	FDA - EU	-268 +260	Food & Pharma, soft surfaces
N-088	Ptfe-poliimide	yellow		-268 +260	High wear resistance. Soft surfaces
N-074	PEHMW	white	FDA	-140 +80	High wear and extrusion resistance
P95-A252	Polyurethane	blue	FDA	-50 +105	Extrusion and wear withstanding, low friction coefficient
P95-VI251	Polyurethane	violet	FDA	-30 +115	CIP (clean in place) fluids compatible
P95-R198	Polyurethane	red		-30 +125	Extrusion and wear withstanding, low friction coefficient, high temperatures
P95-AR255	Polyurethane	orange		-30 +135	Extrusion and wear withstanding, low friction coefficient, higher temperatures
P95-G253	Polyurethane MoS	gray		-30 +105	Extrusion and wear withstanding, lower friction coefficient

CHOOSING Neuflon-ptfe compound ACCORDING WITH FLUID AND SURFACE

SURFACES

Steel HEC>=30-45
Temp. Mart. Inox Steel
Cast Iron HRB<=200
Steel HRC>=45
Cast Iron HRB>200

Galvanic or chemical
surfacing HV>=700
Chromium Bronze

Bronze
Brass

Treated
Aluminium

Aust. Inox Steel
Glass

FLUIDS

NEUFロン-ptfe compounds (standard in bold)

Hydraulic oil
Transmission oil
Fire resistant syntetic
hydraulic oil

N-031
N-032 N-060 N-077 P95-A112

N-031
N-032 N-060 N-077 P95-A112

N-009
N-043 N-032 P95-A112

N-032
N-074 P95-A112

N-009
N-032 N-074 P95-A112

Water and oil/water

N-032

N-032

N-009

N-032

N-009



emulsions	N-060 N-077 N-074	N-060 N-077 N-074	N-043 N-074	N-074	N-032 N-074
Drugs and food	N-009 N-102 N-020 N-043 N-060 N-074 N-088 P95-B113	N-009 N-074 P95-B113	N-102 N-009 P95-B113	N-009 N-074 P95-B113	N-009 N-074 P95-B113
Air	N-032 N-031 N-043 N-074 P95-A112	N-032 N-043 P95-A112	N-032 N-009 N-043 N-074 P95-A112	N-032 N-074 P95-A112	N-032 N-009 N-043 N-074 P95-A112
Steam	N-032 N-043	N-032	N-009 N-032 N-043		N-032 N-009 N-043
Acids and Bases	N-032 N-059 N-074	N-032 N-043 N-074			N-009 N-032 N-043 N-074

ELASTOMER ACCORDING WITH FLUID

FLUID	ELASTOMER
HYDRAULIC OIL - TRANSMISSION OIL	NBR
FIRE RESISTANT SYNTETIC HYDRAULIC OIL	EPDM
WATER AND WATER/OIL EMULSIONS	NBR
FOOD AND DRUG	MVQ
AIR	NBR
STEAM	EPDM - FFKM
ACIDS AND BASES	FKM - FFKM