

Guide rings | Ptfе piston guide rings

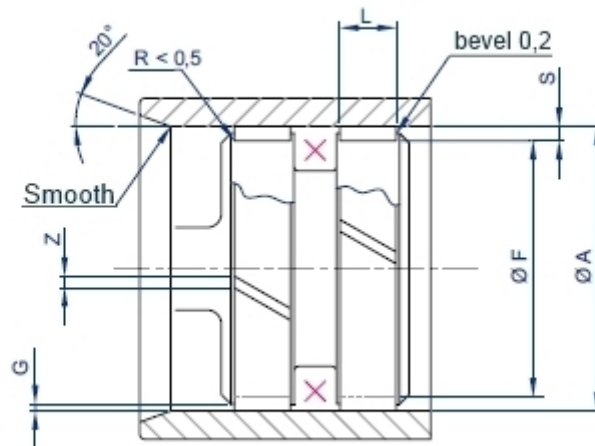

A Neuflon-PTFE compound tape intended to be used as a guiding element

Neuflon N-071 for hydraulic applications

Neuflon N-059 for pneumatic applications

Long life of both the skate and the sliding surface. Low friction and no Stick-Slip. Possibility of dry running. Exceptional resistance to the 'Diesel effect'. Ample thermal and chemical resistance. Ready availability from coils.



SEAT

Cross Section Code	S Thickness	F groove diameter	L groove width	G piston-cylinder clearance	Z gap clearance	length
		j8 - h8	H11	max S x 0,4		+0 / -0,3
HD SP 3,2/1,5	1,5		3,2			
HD SP 3,2/2,5	2,5		3,2			
HD SP 4,2/1,5	1,5		4,2			
HD SP 4,2/2,5	2,5		4,2			
HD SP 6,3/1,5	1,5		6,3			
HD SP 6,3/2,5	2,5		6,3			
HD SP 8,1/1,5	1,5	A - 2 x S	8,1	choice depends on the seal adopted max S x 0,4	1 + A x 0,03	3,14x(A-S)-Z
HD SP 8,1/2,5	2,5		8,1			
HD SP 9,7/2,5	2,5		9,7			
HD SP 15/2,5	2,5		15			
HD SP 20/2,5	2,5		20			
HD SP 25/2,5	2,5		25			
HD SP 30/2,5	2,5		30			

Coding example

housing class: HDSP
 Section: 9,7/2,5 (thikness 2.5 width 9.7)
 Material: N-071 (hydraulics)
 Bore: 100

HDSP - 9,7/2.5 - N-071 - 100



MATERIALS

ELASTOPLASTIC DEFORMATION / LOAD			FRICTION COEFFICIENT / SPEED	
	Image		Image	
CHARACTERISTICS	SPECIFICATION	UNITS	MATERIAL	
			NEUFLON-071	NEUFLON-059
SPECIFIC LOAD Qs T <=100°C		N.mm-2	2.5	2.6
Compression modulus at 1% of deformation	D695-54	N.mm-2	8	8.40
Hardness	D53505	Shore D	60	65
Friction Coefficient			0.12	0.13
Max. Speed		m/sec	5	5
Thermal expansion coefficient	D696-70	10 ⁻⁶ / °C	90	85
Continual operational Temp.		°C	250	250
Peak Temperature		°C	300	300
Compatible with hydraulic oil			yes	yes
Compatible with water/oil emulsions			yes	yes
Compatible with DOT 3 DOT4			yes	yes
Compatible with water			no	yes
Compatible with phosphoric esters			yes	yes
Flammability	D635-68		fire resistant	fire resistant