

Guarnizioni Parker Seals | Parker Z9 tenuta stelo

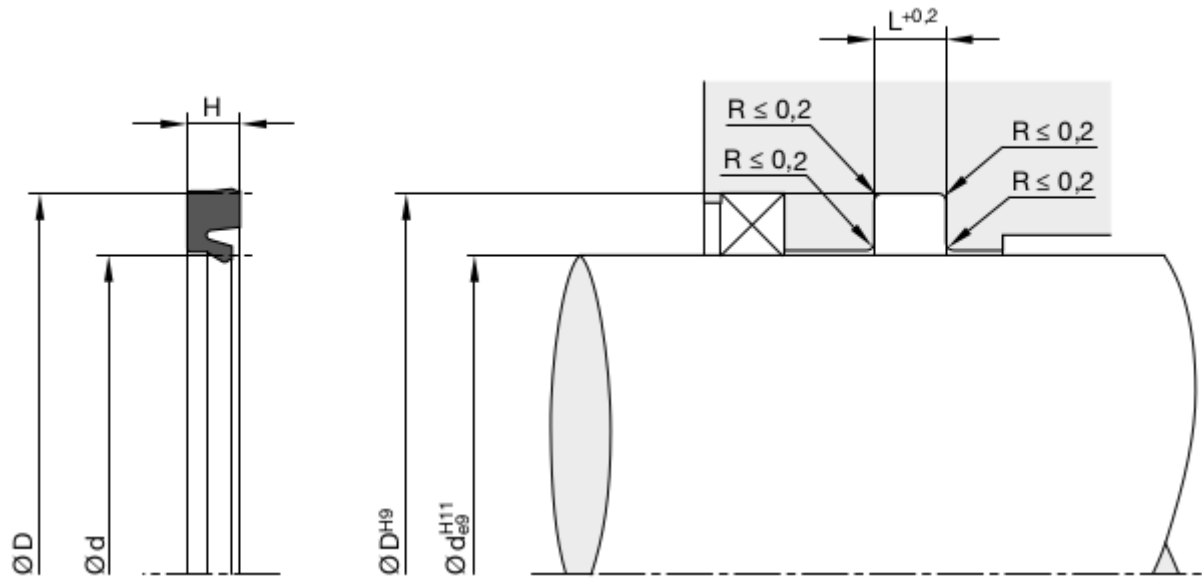

Compound N3580
 Pressione Max. 16 bar.
 Temp. max.g -20 +80 °C.
 Velocità Max. 1 m/sec.



SEDI

d h9 stelo	D H9 fondo gola	H ingombro	L +0.5 larghezza gola	codice Z9
3	6	2.2	2.6	Parker Z9 0303 N3580
3	6.5	2.2	2.6	Parker Z9 0304 N3580
10	16	2.55	35	Parker Z9 1004 N3580
12	18	2.55	3	Parker Z9 1204 N3580
16	22	2.55	3	Parker Z9 1605 N3580
17	24	2.55	3	Parker Z9 1724 N3580